

ESTAdry D-Type, LVAC Power Capacitors



FEATURES

- Self-healing technology
- Over pressure tear-off fuse
- Smallest available height for 50 kvar units: 210 mm (+ 68 mm for terminals)
- Excellent heat dissipation
- Screw-on terminal with M10 bolts
- Resin filling provides thermal conductivity similar to that of oil-filled capacitors
- Aluminum case is welded and hermetically sealed
- No paint required for OUTDOOR application
- UL and cUL approved

APPLICATIONS

- Areas with dust and moisture, which require a high degree of protection and high creepage distances. Also for OUTDOOR
- Free standing, fixed individual-PFC (e.g. motors, lighting, transformers)
- Automatic central-PFC (e.g. group of loads)
- Harmonic trap (e.g. UPS, frequency drives, converter)
- Pole mounted PFC

QUICK REFERENCE DATA		
Series	PhMKDg..., triangular	PhMKDgF..., triangular
Description	ESTAdry D-type, LVAC power capacitors - dry - INDOOR , IP00	ESTAdry D-type, LVAC power capacitors - dry - OUTDOOR , IP00
Type	Capacitors, fixed, low voltage	Capacitors, fixed, low voltage
Technology	MKP, metallized polypropylene film	MKP, metallized polypropylene film
Voltage max. (V)	1000	1000
Capacitance min. (μF)	3-phase D: 3 x 115.5, 3-phase Y: 3 x 140.1	3-phase D: 3 x 115.5, 3-phase Y: 3 x 140.1
Capacitance max. (μF)	3-phase D: 3 x 331.6, 3-phase Y: 3 x 334.3	3-phase D: 3 x 331.6, 3-phase Y: 3 x 334.3
Output min. (kvar)	30	30
Output max. (kvar)	56.2	56.2



CAPACITORS IN TRIANGULAR CASING

DESCRIPTION

The PhMKDg series capacitor in a triangular aluminum case with a standard rating of 50 kvar, augments Vishay ESTA broad line of reliable three-phase power capacitors. The PhMKDg series is preceded by our PhMKP and the ESTAdry PhMKPg series in aluminum tubular casings, with outputs up to 37 kvar, depending on their rated voltage.

The standard PhMKDg series capacitor is designed for indoor application, with externally arranged discharge resistors ($U \leq 50 \text{ V}/60 \text{ s}$). For outdoor application, the discharge resistors can be incorporated internally ($U \leq 75 \text{ V}/180 \text{ s}$). Also, the pure aluminum welded cases render these capacitors perfectly suitable for outdoor use.

The PhMKDg capacitor can be used for both controlled equipment and for stationary or mobile fixed compensation, e.g. for induction-motor-operated conveyer belts in the mining industry.

The indoor capacitor can be supplied with the option of a small protective cover for each individual connection or with an IP53-type overall protective cover.

The triangular case and corresponding triangular arrangement of the winding elements allows for simple connection in parallel of several units (IN-LINE). The joint insulation created by means of a solid ceramic terminal base with high surface-creepage resistance and very long tracking paths establishes an additionally superior mechanical stability for the three solid connector bolts.

With a resin filled pure aluminum case offering superior mechanical stability, low profile design, excellent thermal conductance, easy paralleling and a complete three-phase tear-off fuse system incorporated into the PhMKDg design, this series is the ideal first choice for new designs and applicable retrofit requirements.

3-PHASE CAPACITOR, INDOOR



Single bolt protection



IP53

3-PHASE CAPACITOR, OUTDOOR



**ESTAdry D-TYPE PhMKDg, INDOOR**

TECHNICAL DATA	
STANDARDS	IEC 60831-1 + 2, EN 60831-1 + 2, UL810 LATEST EDITION UL/ULC FILE # E97723
Overvoltages (in accordance with the above standards)	$U_{cn} + 10\%$ (up to 8 h daily) $U_{cn} + 15\%$ (up to 30 min daily) $U_{cn} + 20\%$ (up to 5 min, only 200 times in the life of the capacitor) $U_{cn} + 30\%$ (up to 1 min, only 200 times in the life of the capacitor) Please also refer to "Terms and Definitions".
Overcurrent (in accordance with the above standards)	$1.3 \times I_n$, $1.5 \times I_n$ with 10 % overvoltages, 15 % over capacitance and harmonics included, continuous operation Please also refer to "Terms and Definitions".
Tolerance on capacitance	- 5/+ 10 % in accordance with the standards $\pm 5\%$ as Vishay ESTA standard
Test voltage, terminal/terminal	$2.15 \times U_{cn}$, VAC, 2 s (routine test)
Test voltage, terminal/casing	6000 VAC, 2 s (routine test)
Inrush current	300 times rated current I_n
Losses	≤ 0.4 W/kvar to 0.5 W/kvar (without discharge resistors)
Statistical life expectancy	> 130 000 operating h (ESTAdry)
Degree of protection	IP00 (terminal cover for higher protection class upon request), indoor
Ambient temperature category	- 25/D (max. 55 °C), (- 40/D on request)
Permitted casing temperature	Max. 65 °C (measured on top of the can)
Cooling	Naturally air-cooled
Permissible relative humidity	Maximum 95 %
Maximum allowed altitude	2000 m above sea level
Mounting position	Vertical and horizontal
Mounting and grounding	Threaded M12 stud at the bottom of the container
Safety features	All-phase overpressure tear-off fuse, self-healing
Casing	Aluminum can, welded top
Dielectric	Polypropylene film, self-healing
Filling agent	Resin-filled (ESTAdry), non-PCB, non-toxic
Terminals	Threaded studs M10

3-PHASE CAPACITORS IN TRIANGULAR CASING, INDOOR

TYPE	ARTICLE NO. (1)	RATED VOLTAGE V	RATED OUTPUT kvar	CAPACITANCE μ F	CURRENT A (50 Hz)	WEIGHT kg	HEIGHT H mm
PhMKDg400.3.50	5345-44814-xx	400	50	3 x 331.6 Δ	72.2	4.0	210
PhMKDg440.3.50	5345-44804-xx	440	50	3 x 274.0 Δ	65.6	4.0	210
PhMKDg440.3.56, 2	5345-44805-xx	440/415	56.2/50	3 x 308.0 Δ	73.7/69.6	4.0	210
PhMKDg460.3.50	5345-44803-xx	460	50	3 x 250.7 Δ	62.8	4.0	210
PhMKDg525.3.50	5345-44806-xx	525	50	3 x 192.5 Δ	55.0	4.0	210
PhMKDg690.2.50	5345-44807-xx	690	50	3 x 334.3 Y	41.8	4.0	210
PhMKDg760.2.50	5345-44808-xx	760	50	3 x 275.5 Y	38.0	4.0	210

ORDERING INFORMATION

Packing units	1 piece per carton
---------------	--------------------

Notes

- Other voltage ratings, outputs, and frequencies on request.
- (1) Version no. xx may differ as it respects small changes, e.g. on the label

DIMENSIONS, INDOOR

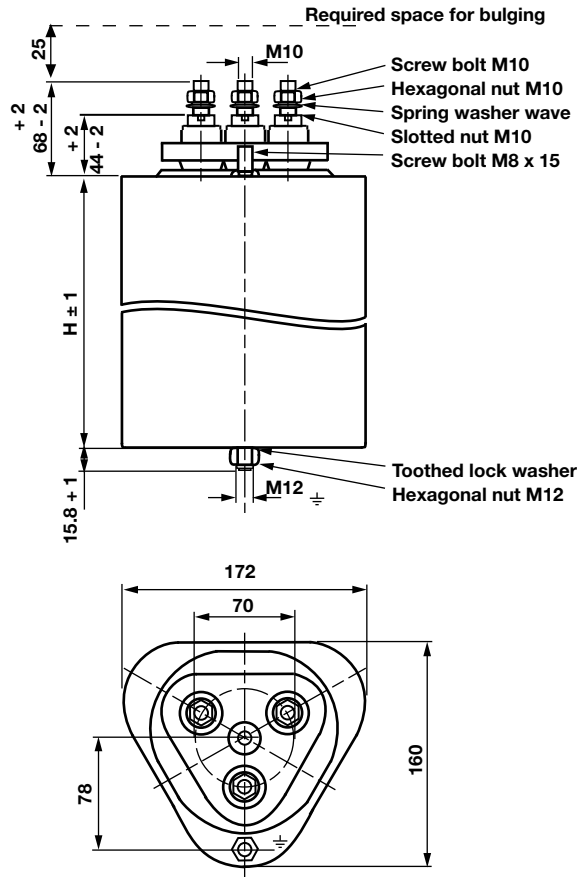

Drawing 6

DISCHARGE RESISTORS

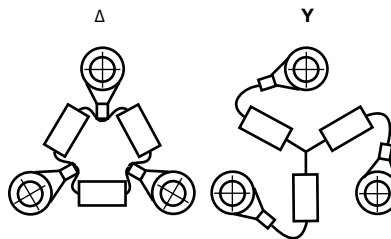

RECOMMENDED TORQUES	
STYLE	RECOMMENDED TORQUE
Terminals M8	6 Nm
Terminals M10	10 Nm
M12 mounting stud	10 Nm

**ESTAdry D-TYPE PhMKDgF, LVAC POWER CAPACITORS, OUTDOOR**

TECHNICAL DATA	
STANDARDS	IEC 60831-1 + 2, EN 60831-1 + 2, LATEST EDITION
Overvoltages (in accordance with the above standards)	U _{cn} + 10 % (up to 8 h daily) U _{cn} + 15 % (up to 30 min daily) U _{cn} + 20 % (up to 5 min, only 200 times in the life of the capacitor) U _{cn} + 30 % (up to 1 min, only 200 times in the life of the capacitor) Please also refer to "Terms and Definitions".
Overcurrent (in accordance with the above standards)	1.3 x I _n , 1.5 x I _n with 10 % overvoltages, 15 % over capacitance and harmonics included, continuous operation "Please also refer to Terms and Definitions".
Tolerance on capacitance	- 5/+ 10 % in accordance with the standards ± 5 % as Vishay ESTA standard
Test voltage, terminal/terminal	2.15 x U _{cn} , VAC, 2 s (routine test)
Test voltage, terminal/casing	6000 VAC, 2 s (routine test)
Inrush current	300 times rated current I _n
Losses	≤ 0.4 W/kvar to 0.5 W/kvar (without discharge resistors)
Statistical life expectancy	> 130 000 operating h (ESTAdry)
Degree of protection	IP00 outdoor
Ambient temperature category	- 25/D (max. 55 °C), (- 40/D on request)
Permitted casing temperature	Max. 65 °C (measured on top of the can)
Cooling	Naturally air-cooled
Permissible relative humidity	Maximum 95 %
Maximum allowed altitude	2000 m above sea level
Mounting position	Vertical and horizontal
Mounting and grounding	Threaded M12 stud at the bottom of the container
Safety features	All-phase overpressure tear-off fuse, self-healing
Casing	Aluminum can, welded top
Dielectric	Polypropylene film, self-healing
Filling agent	Resin-filled (ESTAdry), non-PCB, non-toxic
Terminals	Threaded studs M10

Available types same as for indoor use, different type designation "F".
For example:

TYPE	RATED VOLTAGE V	RATED OUTPUT kvar	CAPACITANCE µF	CURRENT A (50 Hz)	WEIGHT kg	HEIGHT H mm
PhMKDgF460.3.50	460	50	3 x 250.7 Δ	62.8	4.0	210

ORDERING INFORMATION

Packing units	1 piece per carton
---------------	--------------------

RECOMMENDED TORQUES

STYLE	RECOMMENDED TORQUE
Terminals M8	6 Nm
Terminals M10	10 Nm
M12 mounting stud	10 Nm

Note

- Other voltage ratings, output, and frequencies upon request



DIMENSIONS, OUTDOOR

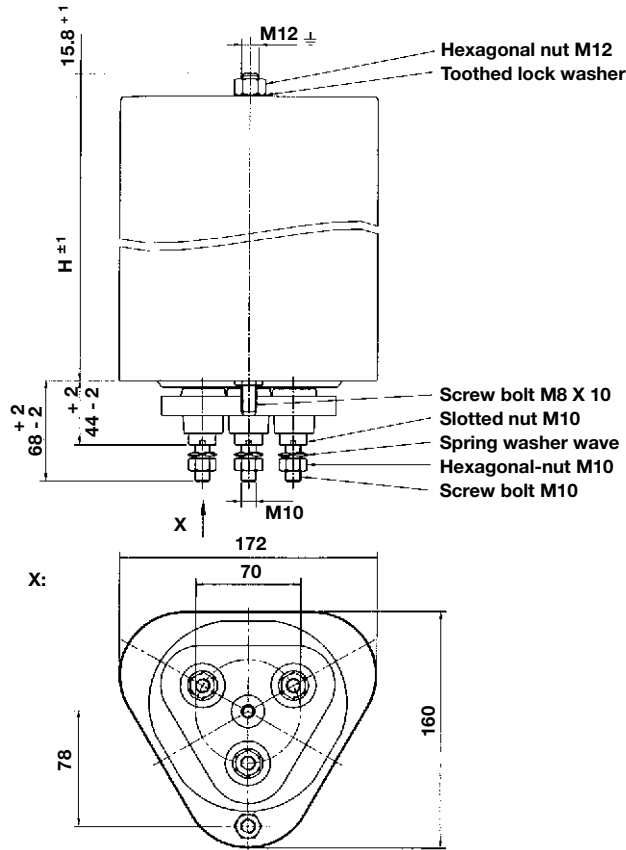

Drawing 7

ACCESSORIES: SUPPORT FOR POLE AND WALL MOUNTING

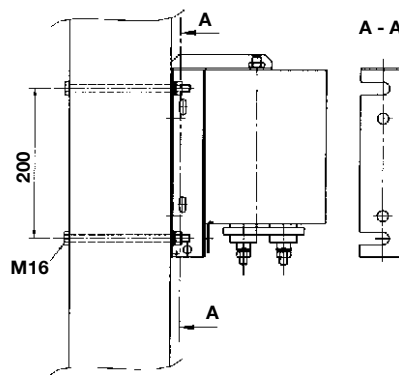



Disclaimer

ALL PRODUCT, PRODUCT SPECIFICATIONS AND DATA ARE SUBJECT TO CHANGE WITHOUT NOTICE TO IMPROVE RELIABILITY, FUNCTION OR DESIGN OR OTHERWISE.

Vishay Intertechnology, Inc., its affiliates, agents, and employees, and all persons acting on its or their behalf (collectively, "Vishay"), disclaim any and all liability for any errors, inaccuracies or incompleteness contained in any datasheet or in any other disclosure relating to any product.

Vishay makes no warranty, representation or guarantee regarding the suitability of the products for any particular purpose or the continuing production of any product. To the maximum extent permitted by applicable law, Vishay disclaims (i) any and all liability arising out of the application or use of any product, (ii) any and all liability, including without limitation special, consequential or incidental damages, and (iii) any and all implied warranties, including warranties of fitness for particular purpose, non-infringement and merchantability.

Statements regarding the suitability of products for certain types of applications are based on Vishay's knowledge of typical requirements that are often placed on Vishay products in generic applications. Such statements are not binding statements about the suitability of products for a particular application. It is the customer's responsibility to validate that a particular product with the properties described in the product specification is suitable for use in a particular application. Parameters provided in datasheets and/or specifications may vary in different applications and performance may vary over time. All operating parameters, including typical parameters, must be validated for each customer application by the customer's technical experts. Product specifications do not expand or otherwise modify Vishay's terms and conditions of purchase, including but not limited to the warranty expressed therein.

Except as expressly indicated in writing, Vishay products are not designed for use in medical, life-saving, or life-sustaining applications or for any other application in which the failure of the Vishay product could result in personal injury or death. Customers using or selling Vishay products not expressly indicated for use in such applications do so at their own risk. Please contact authorized Vishay personnel to obtain written terms and conditions regarding products designed for such applications.

No license, express or implied, by estoppel or otherwise, to any intellectual property rights is granted by this document or by any conduct of Vishay. Product names and markings noted herein may be trademarks of their respective owners.

Material Category Policy

Vishay Intertechnology, Inc. hereby certifies that all its products that are identified as RoHS-Compliant fulfill the definitions and restrictions defined under Directive 2011/65/EU of The European Parliament and of the Council of June 8, 2011 on the restriction of the use of certain hazardous substances in electrical and electronic equipment (EEE) - recast, unless otherwise specified as non-compliant.

Please note that some Vishay documentation may still make reference to RoHS Directive 2002/95/EC. We confirm that all the products identified as being compliant to Directive 2002/95/EC conform to Directive 2011/65/EU.

Vishay Intertechnology, Inc. hereby certifies that all its products that are identified as Halogen-Free follow Halogen-Free requirements as per JEDEC JS709A standards. Please note that some Vishay documentation may still make reference to the IEC 61249-2-21 definition. We confirm that all the products identified as being compliant to IEC 61249-2-21 conform to JEDEC JS709A standards.